

(Title)

Home Electrical Protection Beyond the Code: Arc-Fault Circuit Interrupters

ABSTRACT

The UL and CPSC concluded, in 1995, that circuit breakers able to trip when they detect either an arc or ground fault are ‘very promising’ in protecting against electrical fires. Subsequent development and testing by Eaton|Cutler-Hammer research engineers and others have clearly verified that conclusion, and, as a consequence, all of today’s AFCI circuit breakers, available from four manufacturers, protect against both arc and ground faults.

Ground fault protection is a “hidden” benefit; it is not required today by UL1699, the AFCI Standard. Nevertheless, Eaton|Cutler-Hammer has chosen to ‘dual-list’ its breakers to UL1699 and either UL1053, Ground-Fault Sensing or Relaying Equipment; or UL943, Ground-Fault Circuit Interrupter. This paper examines the process by which such ‘Dual-Listed’ breakers protect against the eleven recognized types of electrical wiring faults.

(HEAD) BACKGROUND: A STUDY IS THE FOUNDATION FOR SAFER RESIDENCES.

“Arc fault detection appears to be a very promising technology [for protecting against electrical fires] especially when added to residential branch circuit breakers and combined with other proven technologies such as ground fault protection.”

Underwriters Laboratory, Inc. (UL), in a 1995 report¹ of a study underwritten by the Consumer Product Safety Commission (CPSC).

The benchmark study subjected ten new technology-based devices to a series of recognized home electrical fire hazards broadly classified as insulation failure, loose connections, overheated conductors, and broken conductors. After the study was complete, NEMA and UL wrote a standard—UL1699, Arc Fault Circuit Interrupters. Eaton|Cutler-Hammer (C-H hereafter) introduced, in 1997, the first products that met the standard². The breakers are listed to UL1699 and either UL1053, Ground-Fault Sensing and Relaying Equipment, or UL943, Ground-Fault Circuit Interrupter.

(HEAD)THE IMPORTANCE OF DUAL LISTING

C-H research engineers identified eleven hazards [including hazards identified by the UL/CPSC study] in residences that can cause either high-resistance series faults (which are not hazards in themselves, but can become one), or ground or arcing faults (which are hazardous).

	<i>Hazardous Wiring Faults that are either →</i>	<i>High Resistance Series Faults, (not hazards in themselves) or →</i>	<i>Arcing or Ground Faults (which are always hazardous)</i>	<i>They are mitigated by combined AFCI and GFI protection (all AFCI circuit breakers include both types of protection)</i>
in-wall wiring	1. Aluminum wire	Yes	Yes	Yes
	2. Glowing contacts	Yes	Yes	Yes
	3. Glowing wire nuts	Yes	Yes	Yes
	4. Back-wired push-in receptacle connections	Yes	Yes	Yes
	5. Shared neutrals	Yes	Yes	Yes
	6. Hot plugs	Yes	Yes	Yes
	7. Metallic bridging, NM-B or Romex™	No	Yes	Yes
in-room wiring	8. Metallic bridging SPT-2	No	Arcing only	Yes
	9. Broken conductors, SPT-2	Yes	Arcing only	Yes
	10. Overheated cords, SPT-2	Yes	Yes	Yes
	11. Overheated cord-plug connections	Yes	Yes	Yes

Seven of the hazards (1 through 7) are caused directly by the installation, design or construction of the hidden in-wall wiring; four (8 through 11) are caused by poor construction or abuse of the in-room wiring. Nine of the eleven wiring faults start as series faults and evolve into either arcing or ground faults.

(Sub) Hazards Related to Design and Construction of a Home's In-Wall Electrical System

1. Aluminum wiring, popular in the 1970s and extant in thousands of homes, is no longer installed in 15 or 20 ampere circuits. It is well known and documented that a high-resistance connection hazard can develop at wiring device terminations. The resulting high temperature can cause insulation to fail, then a line-to-neutral or line-to-ground arcing fault, or a ground-to-neutral fault, to develop. The latter is not an arcing fault since the ground and neutral conductors are at the same potential; however, there are risks of fire or shock from the grounded neutral.
2. Glowing contacts² are caused by a coating of copper oxide formed by the movement of copper wire at loose wiring device screw terminals. The result is a high-resistance connection fault that causes the wire to overheat and glow like the coil of a toaster, melting the wire insulation and the thermal plastic case of the wiring device, leading to either an arcing or ground fault.
3. Glowing wire nuts develop when improper installation increases the resistance of the wire-to-wire connection. The heat melts the plastic nut and the wire insulation, allowing normally isolated conductors to touch, leading to an arcing or ground fault.
4. Back-wired, push-in receptacle connections³ are wired to the available push-in connections at the rears [rather than the screw connections at the sides] of receptacles. The push-in connections tend to loosen over time, creating a high resistance contact and an arcing or ground fault.
5. Shared neutrals are caused when a single neutral is shared with two line conductors of the same phase, a 'shared neutral hazard' that is always the result of a wiring error. The 'shared neutral' carries the sum of the two line currents, creating a serious overload.

However, shared neutrals are allowed by the NEC when a three-conductor plus ground wire replaces two, two-conductors plus two ground wires to supply two 120V branch circuits (a 'homerun'), provided the line voltages are derived from opposite phases of the 120/240V

service. The current carried by the neutral in a homerun is the difference—not the sum—of the two line currents, assuring that it is less or the same as the line currents.

Electricians often utilize ‘homeruns’ to reduce labor cost. To accommodate them, C-H offers a family of two-pole Branch/Feeder AFCIs, available with both independent and common overload/overcurrent trips. An arcing or ground fault trip is always a common trip as the fault may be in the three-conductor plus ground wire, and thus both branch circuits should be de-energized.

6. Hot plugs—plugs that are hot to the touch—develop when a coating of copper oxide forms on the plug after repeated in/out cycles. The plug/receptacle interface can become so hot that the plug’s plastic insulation and the receptacle melt, ultimately causing an arcing fault at the plug (in-room) or an arcing or ground fault in the associated receptacle (in-wall).

7. Metallic bridging of NM-B or Romex™ can occur due to an over-tightened wire staple or other physical damage to the wire that results in an unintended conductive metallic bridge forming between normally isolated conductors. If the line conductor is involved, there will be an arcing fault; if the ground and neutral conductors are involved, there will be a ‘grounded neutral’. A ground fault interrupter that is UL1053 listed will trip if the neutral conductor is grounded; a similar device that is UL943 listed will trip whether or not load current is involved.

(Sub) Hazards Related to Poor Construction or Abuse of the Home's In-Room Electrical System

8. Metallic Bridging, SPT-2, “zip” cord, can occur if a metallic object such as a metal chair leg damages a two-conductor, ungrounded appliance cord, setting the stage for a line-to-neutral arcing fault.
9. Broken conductors, SPT-2, are caused by repeated flexing, for instance, of a hair-dryer's cord. UL has found that, although all strands may be broken, elasticity of the insulation can maintain the continuity of the current through the high resistance series fault. Under such conditions, the temperature of the cord can rise enough to pyrolyse the insulation, leading to a parallel arcing fault.
10. Overheated cords, SPT-2, are caused, for example, by routing the cord under a rug or energizing it while it is coiled (the rating of a cord assumes that it is cooled by surrounding air). Overheated insulation can carbonize and develop into either a parallel arcing or ground fault.
11. Overheated cord-plug connections are caused by poor-quality plugs, particularly those that utilize crimps rather than welds to connect multi-strand wires to the plug stabs. The temperature of such a connection can overheat both the wire insulation and the receptacle plastic and, if not detected, will soon compromise the insulation and cause a parallel arcing or ground fault.

Please refer to Appendix II for detailed descriptions of the hazards.

(Sub) Example: The Enhanced Protection of ‘Dual-Listed’ Breakers

‘Dual-Listed’ breakers provide the highest level of protection against all of the eleven faults, regardless of the type of fault (series, arcing, or ground) or its location (in-wall or in-room wiring). For example, the breaker functions as follows when a glowing contact develops at a receptacle terminal in an outlet box:

1. When a glowing contact develops at a line terminal, the black insulation melts, enabling the bare wire to touch the white neutral conductor, bare ground conductor, or grounded metal outlet box. A line-to-neutral arcing fault or a line-to-ground ground fault then develops that trips the combination breaker. The receptacle plastic also melts. A UL study, funded by C-H, has shown that receptacle melting can cause an internal line-to-receptacle frame ground fault. In all cases, a ‘Dual-Listed’ breaker will trip.
2. When a glowing contact develops at the neutral terminal, the conductor’s white insulation will melt. If the conductor touches the black line conductor, there will be a line-to-neutral arcing fault. If the conductor touches ground, there will be a grounded-neutral fault as part of the returning load current will return via the ground path. Either fault will cause a ‘Dual-Listed’ breaker to trip.
3. It is also possible that the glowing conductor will weaken and break, causing the fault to self extinguish. This safe condition is easily detected, as outlets downstream of the break will be dead.

In all three cases, a glowing contact at a wiring device terminal is returned to a safe condition by ‘Dual-Listed’ circuit breakers that protect branch circuits⁴.

(See Appendix III for a detailed review of the design and function of ‘Dual-Listed’ breakers.)

(HEAD) SUMMARY:

(Copy) The 2002 NEC for the first time requires that Arc Fault Circuit Interrupters must protect the complete branch circuit feeding bedroom outlets.

210.12 Arc-Fault Circuit-Interrupter Protection.

(A) Definition. *An arc-fault circuit interrupter is a device intended to provide protection from the effects of arc faults by recognizing characteristics unique to arcing and by functioning to de-energize the circuit when an arc fault is detected.*

(B) Dwelling Unit Bedrooms. *All branch circuits that supply 125-volt, single-phase, 15- and 20-ampere outlets installed in dwelling unit bedrooms shall be protected by an arc fault circuit interrupter listed to provide protection of the entire branch circuit.*

The NEC definition of a branch circuit is:

Branch Circuit. *The circuit conductors between the final overcurrent device protecting the circuit and the outlet(s).*

Based on the investigation outlined in this report we believe that AFCI protection is desirable for all branch circuits supplying residential living areas such as family rooms, dining rooms, living rooms, hallways, etc. as soon as possible, certainly by the end of the next code cycle.

Further to provide enhanced protection both arcing and ground fault protections should be considered. This can be accomplished easily since all of today's available AFCIs include both types of protection.

(HEAD) FOR MORE INFORMATION...

(Copy)

For technical AFCI information contact Dr. Joseph C. Engel, Manager, Electronics Research and Development, Cutler-Hammer, Technology and Quality Center, 170 Industry Drive, RIDC Park West, Pittsburgh, PA 15275/ (412) 494-3060 or JosephCEngel@Eaton.com

For Cutler-Hammer AFCI product information contact Brendan A. Foley, Product Manager, Cutler-Hammer, Headquarters, 1000 Cherrington Pkwy, Moon Township, Pittsburgh, PA 15108/ (412) 893-3870 or BrendanAFoley@Eaton.com

Appendix I

Types of Electrical Faults as Defined in the UL/CPSC Report

1. Series Faults

Series (Continuity) Fault - A partial or total local failure in the intended continuity of a conductor characterized by either infinite resistance (a completely severed conductor) or by resistance that alternates between infinite resistance and high or normal resistance such as intermittent connection at a loose wiring terminal or splice.

Note: A series fault may contribute to the development of an insulation fault.

High Resistance Series Fault – A series fault characterized by the presence of abnormally high resistance (high resistance in comparison to the normal resistance of the normal conductor but not high in comparison to the infinite resistance of a completely severed conductor) in a wire termination, or wire splice, resulting in a reduction of ampacity and excess of heat dissipation at the fault. Examples are a partially severed stranded conductor with only a small percentage of the strands intact and a corroded wiring terminal or splice.

Note: A series fault may contribute to the development of an insulation fault.

Series Arcing Fault – A series fault at which arcing occurs.

Series Fault Heating – Heat generated at the site of a series fault

2. Parallel Faults

Across-the-Line Fault – An insulation fault between an ungrounded circuit conductor and either a 1) grounded circuit conductor, or 2) another ungrounded circuit conductor. Also referred to as a parallel fault.

Across-the-Line Arcing Fault – An across-the-line fault at which arcing occurs. May also be referred to as a parallel arcing fault.

Ground-Fault Circuit – A circuit formed as a result of a line-to-ground fault.

Line-to-Ground Fault – An insulation fault between an ungrounded circuit and either 1) an equipment grounding conductor or 2) grounded metal. May also be referred to as a ground fault.

The two types of faults (series and parallel) ultimately can become high-energy hazardous parallel arcing faults in the following ways:

1. A failure of insulation between conductors of a cord such as those on hairdryers, typically the result of physical damage or breakage of the conductors followed by overheating of the insulation due to the high resistance series fault.
2. Metallic bridging of either the line-to-neutral or line-to-ground conductors, for example, by a metal chair resting on a cord or a staple holding a Romex™ wire too tightly, resulting in a parallel fault.

Regardless of the fault type, UL has demonstrated that the arcing currents are identical, and:

- Current is limited by the wire's resistance from the fault to the provider's transformer;
- Peak value is reduced further by the opposing arc voltage, preventing a conventional breaker from tripping magnetically, and
- Current is sputtering, lowering RMS values, and, in turn, delaying or preventing conventional breakers from tripping⁵.

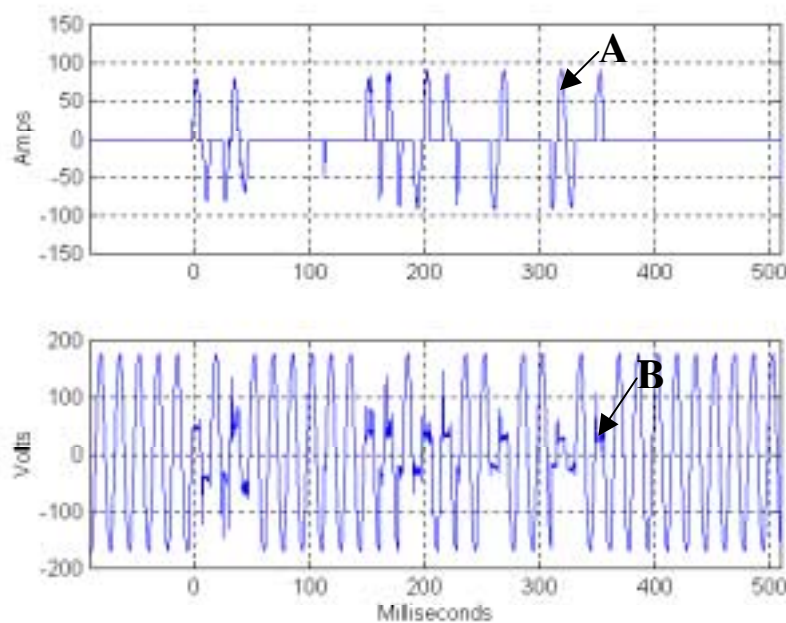

Caption: Assuming an available short circuit fault current of 75 amperes (the accepted minimum), the peak arcing current is only 70 amperes (not the 100 amperes it would be if the fault were a short circuit). Sputtering can lower the RMS value below the 'handle' rating of the breaker.

The arcing condition shown exhibits:

- A ½ cycle average arc current of 50 amps (A) and an average arc voltage of 40 volts (B), resulting in...
- An average power per ½ cycle of arcing of 2000 watts, enabling...
- 200 joules to be absorbed at the fault during the 500 milliseconds shown.

Under these conditions, a conventional breaker would either trip after an unacceptable delay, or not at all. On the other hand, a ‘Dual-Listed’ arc/ground fault circuit breaker would respond rapidly and appropriately. See Appendix III for details of its operations.

Appendix II

Details of the Eleven Hazardous Conditions and the Laboratory Tests that Confirm Them.

(HEAD) RELATED TO DESIGN AND CONSTRUCTION OF THE IN-WALL ELECTRICAL SYSTEM

1. Aluminum wiring need not be discussed further.
2. Glowing contacts develop easily at loose copper wire-to-receptacle terminal connections. A single $\frac{1}{2}$ cycle arc develops at loose screw connections if the wire moves slightly, breaking the connections, and oxides form a high-resistance fault. Continuous arcing is impossible, as Paschen's laws state clearly that copper-to-copper arc discharges cannot be sustained in air in a 120V RMS circuit with a resistive load; a $300V \pm$ peak voltage is needed, and only 170V are available.

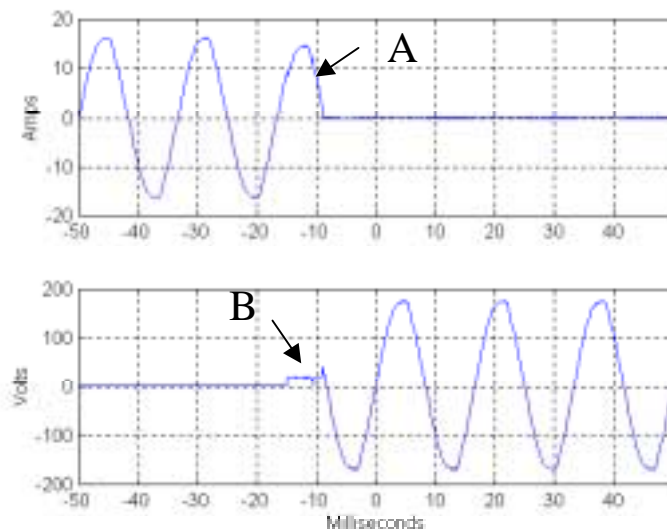

Caption: Contact 'break': Current drops to zero (A) after $\frac{1}{2}$ cycle of arcing (B), when the average power dissipation is 150 watts. Arc voltage=15 volts, energy absorbed < 1 joule.

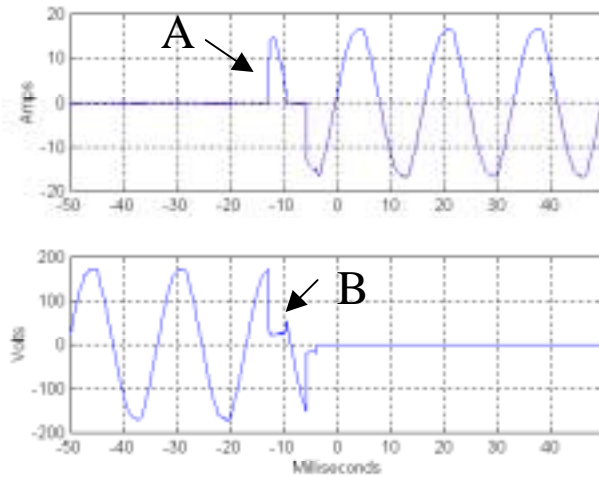

Caption: Contact 'make': The mechanical contacts 'bounce' when closing (A), and there is no continuous arcing (B) after $\frac{1}{2}$ cycle.

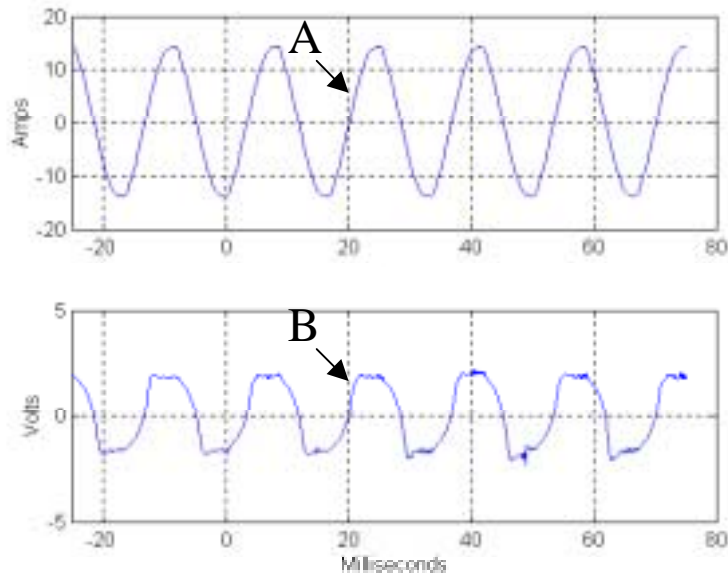

Caption: Repeated contact make/break cycles increase the amount of oxide on the contacts, creating the hazard. The interface can be mechanically strong and, once established, can become permanent, creating current (A) and voltage (B) waveforms such as those shown.

Note: When the current is normal and the voltage drop is only two volts, there is no arcing. A glowing contact once formed is not an arcing fault, but rather a high resistance series fault. Resistance of the contact = $2V / 10A = 0.2 \text{ ohms}$; and power dissipation = $2V * 10A = 20W$, all dissipated in a very small area.

The current waveform is sinusoidal —as it would be without the glowing contact series fault— and the glowing contact is undetectable, as is true for all series faults (see Appendix I) since all involve current flow through a restrictive layer of either copper or aluminum oxide.

The fault's high temperature can melt both the wire and receptacle's insulation, ultimately creating either an arcing or a ground fault. A 'Dual-Listed' circuit breaker will respond to de-energize the branch circuit in either case.

(Sub) The Nature of Oxide Coatings

(Copy)

The copper oxide is a semiconductor with a high negative resistance vs. temperature in the 180-250 degrees Celsius range, over which resistance decreases by as much as five orders of magnitude. As a result, as the temperature rises the current concentrates into a smaller and smaller area, increasing the current density and the temperature of the connection. Temperatures of 1200-1300 degrees Celsius have been cited, hot enough to melt the receptacle's plastic but not the oxide, and to cause the wire's insulation to fail.

(A)



(B)

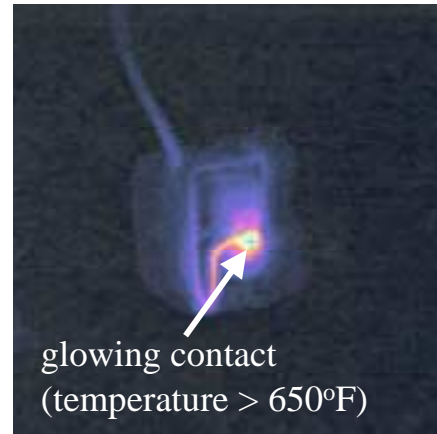

The sequence is as follows:

1. A glowing contact is formed at a receptacle line or neutral terminal (A).
2. The wire glows like a toaster coil, melting the insulation starting at the connection (B).
3. The bare wire can touch other wires in the outlet box, resulting in either an arcing or a ground fault.
4. The heat also melts the plastic in the receptacle, and the plastic drips like wax from a burning candle.
5. The receptacle loses its mechanical integrity, compromising the electrical insulation between conductors.
6. An internal receptacle line-to-ground or neutral-to-ground fault can develop.
7. If an arc fault develops, the receptacle plastic can burn if the upstream breaker does not de-energize the circuit.

(Sub) **Testing Self-extinguishing Plastics: UL498**

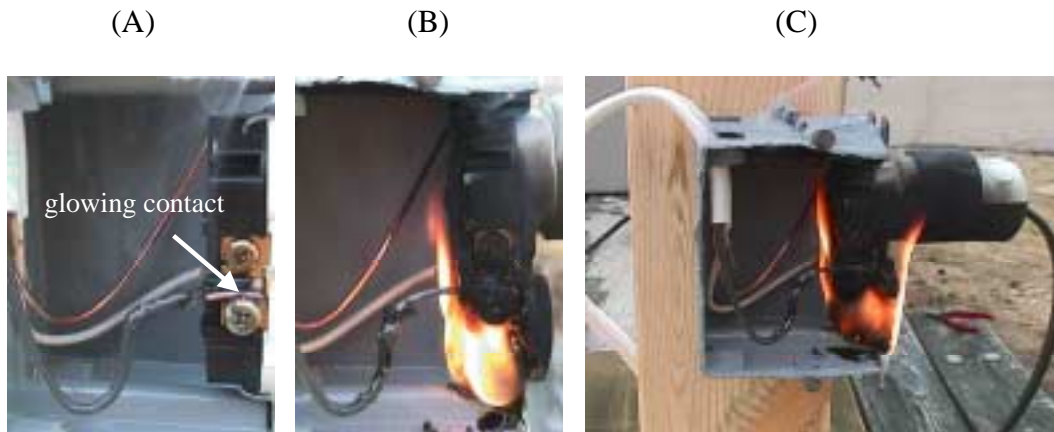

(Copy)

UL498, "Attachment Plugs and Receptacles," approves certain plastics if they self-extinguish after the ignition source is removed; the self-extinguishing properties of some receptacle plastics were tested as follows:

1. A space heater was plugged into a new receptacle mounted in a plastic outlet box, and the side of the box removed for access to the receptacle's terminals.
2. A glowing contact was established at the receptacle terminal (A).
3. A match (the ignition source) was touched momentarily to the plastic as it began to melt, then removed (B).
4. The glowing contact receptacle fire was sustained (C).

(Sub) Testing Self-extinguishing Plastics: UL943



(Copy)

When ground fault circuit interrupting receptacles were tested using the same procedure used for testing attachment plugs and receptacles, the results were identical.

3. Glowing Wire Nuts

(Copy)

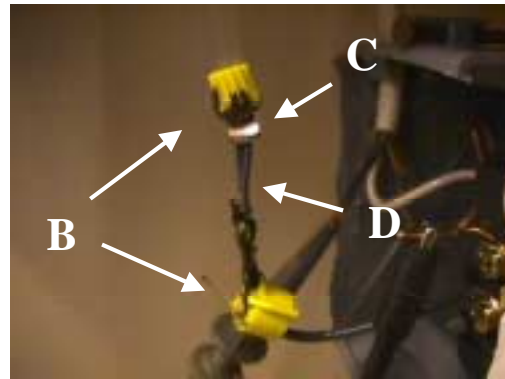
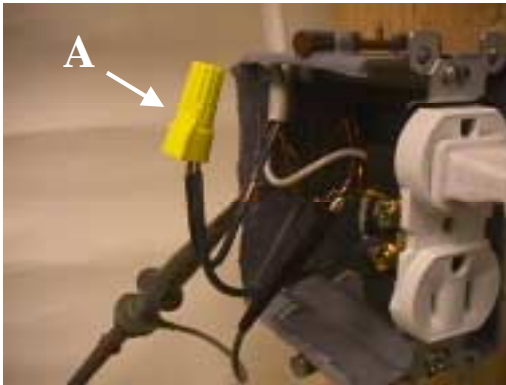

A glowing wire nut was created as follows:

1. A 1200W space heater was plugged into a receptacle.
2. The wire nut (A) was repeatedly loosened and tightened until it felt warm, then left alone.
3. About 15 minutes later, the wire nut had melted completely (B), its steel spring was glowing white-hot (C), and the insulation had melted from the line conductors (D).

4. Back-wired, push-in receptacle connections often are used instead of side-mounted terminal screws, creating hazards that are well documented. In essence, the connections can loosen over time, resulting in a high resistance series fault. In the photo, the back-wired receptacle was used as a feed-through device for a downstream air conditioner, which the homeowner noticed was running poorly. An electrician found that the feeder provided only 98 volts at the air conditioner terminals. The problem was traced to an upstream feed-through receptacle wired using its push-in connections, and that the insulation on the neutral had melted and turned black.

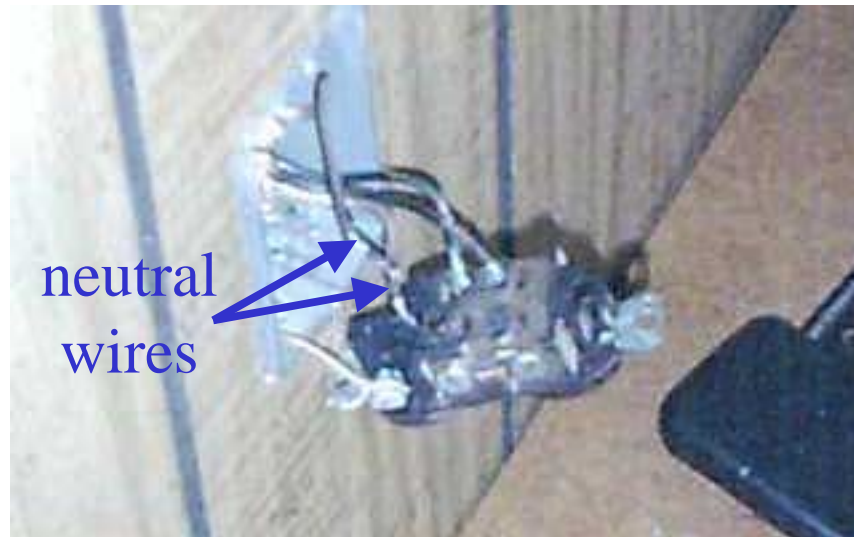

5. Shared Neutrals need not be discussed further.

6. Hot Plugs are caused by the oxide coating that accumulates on the plug and receptacle after repeated plugging and unplugging. The oxide becomes the conductor, its temperature rises, the plastic insulation melts and deforms, and an across-the-line arcing fault develops in the plug.



The above photo clearly shows the ‘in-room’ wiring hazard at the plug. What isn’t apparent without removing the receptacle’s cover plate is the ‘in-wall’ damage to the receptacle and the ‘in-wall’ wiring, which is shown below.



7 and 8. Metallic Bridging with NM-B, Romex™ and SPT-2 need not be discussed further.

9. Broken Conductors, SPT-2, are caused by repeated flexing of a cord⁶. Although the flexing breaks the cord's strands, the circuit is maintained by the elasticity of the insulation.



Caption: A parallel fault can be created by flexing the cord of an appliance (in this case, a hair dryer). However, attempts in the laboratory failed to create a continuous series arc. The cord was flexed until one conductor broke, but not the insulation. Then, with the dryer switched 'on', the cord was stretched and released several hundred times, turning the dryer on and off.

Using the dryer after the cord is broken will carbonize and harden the insulation, which may lead to an across-the-line arcing fault, or the hardened insulation will break and the dryer will not function.

10. Overheated Cords, SPT-2, are caused by any condition that prevents cooling air from circulating around the cord such as routing the cord under a rug or using the cord while it is

rolled up. Over time, the insulation will carbonize and a parallel arcing or ground fault will develop. A 'Dual-Listed' circuit breaker will mitigate against such abuse.

11. Overheated Cord-Plug Connections are caused generally by loose or partial connections between the cord and plug; for example if the connections are crimped instead of welded. The plug shown below, on a new coffeepot, was hot to the touch even though the receptacle and plug were new. It was determined that the plug had a high resistance wire-to-neutral stab connection (A). An infrared photo of the plug and receptacle taken from the side showed the 'in-room' overheated plug (B) as well as the 'in-wall' overheated receptacle neutral terminal (C) and neutral wire (D).

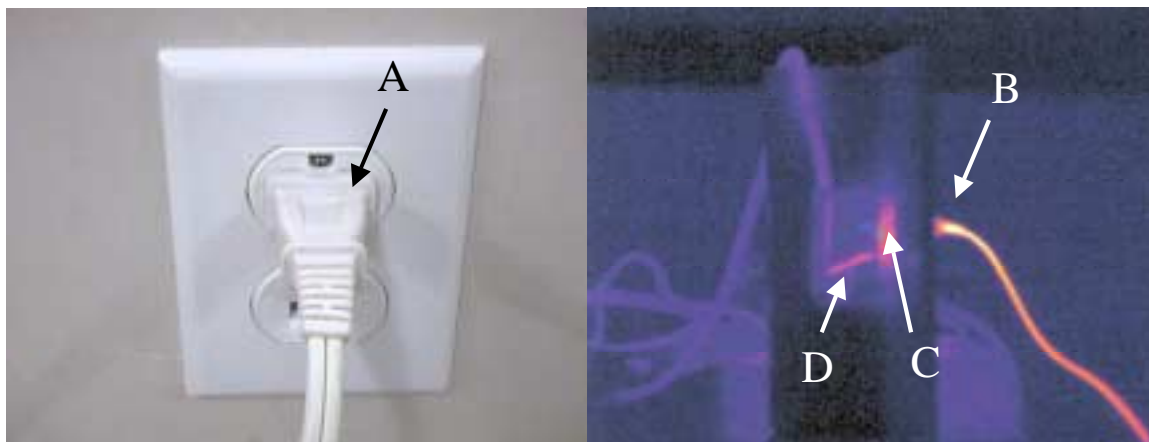

Caption: Connected to the plug by crimping, the appliance cord loosened, then formed a hot spot that exceeded the rating of the STP-2 wire. If ignored, this condition could develop into an arcing or a ground fault that would trip a 'Dual-Listed' circuit breaker.

Appendix III

Design and Function of 'Dual-Listed' Breakers

'Dual-Listed' UL 1699 and UL1053 breakers (single-pole design shown) include:

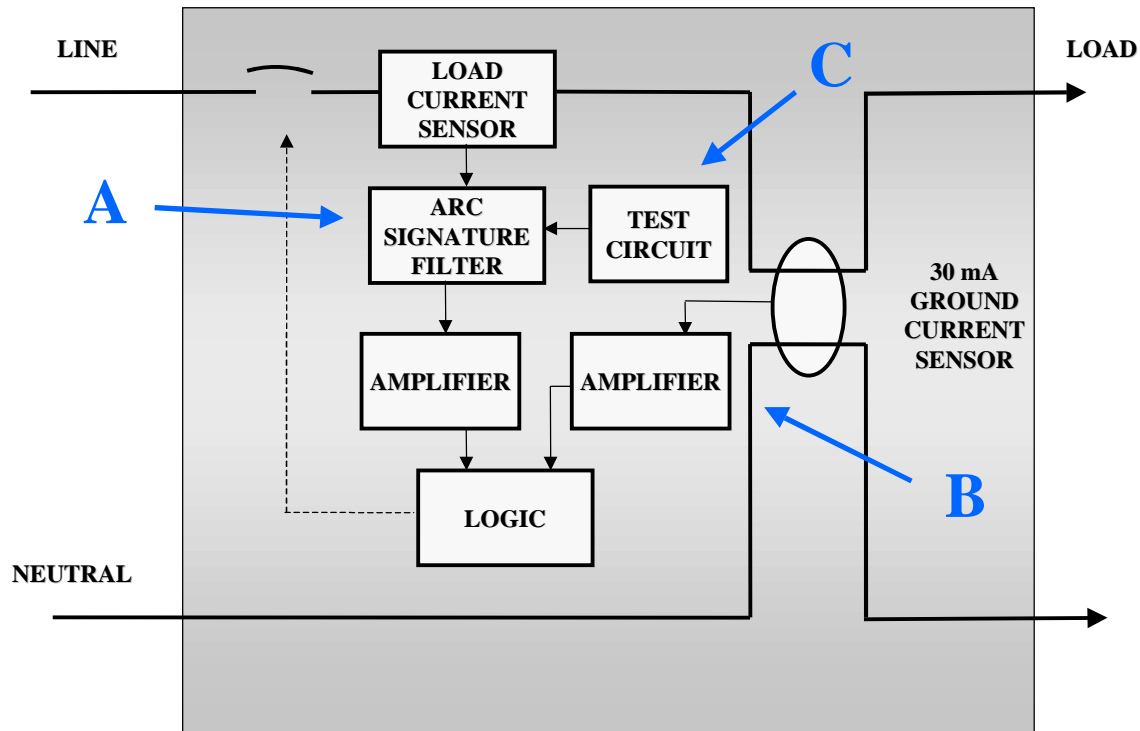

1. Arc-fault sensing circuitry (A) that distinguishes between a safe, normal current and a hazardous arcing fault and trips accordingly. This new breaker protects against:
 - High energy arcing faults caused by insulation damage, and
 - High-resistance-contact series faults that propagate from series to high-energy arcing faults, and are caused by, for example, aluminum wiring connections, glowing contacts, hot plugs, or broken conductors.
2. Ground-fault sensing circuitry (B) that detects both line-to-ground and neutral-to-ground faults and trips the breaker. A UL1699 AFCI would trip due to a line-to-ground arcing fault but not a neutral-to-ground ground fault. Both arcing and ground fault protections are required to mitigate against both types of glowing neutrals faults.

3. Test circuitry (C) verifies the breaker's readiness to trip when it senses an arc fault.

'Dual-Listed' UL1699 and UL943 breakers (two-pole design shown) include:

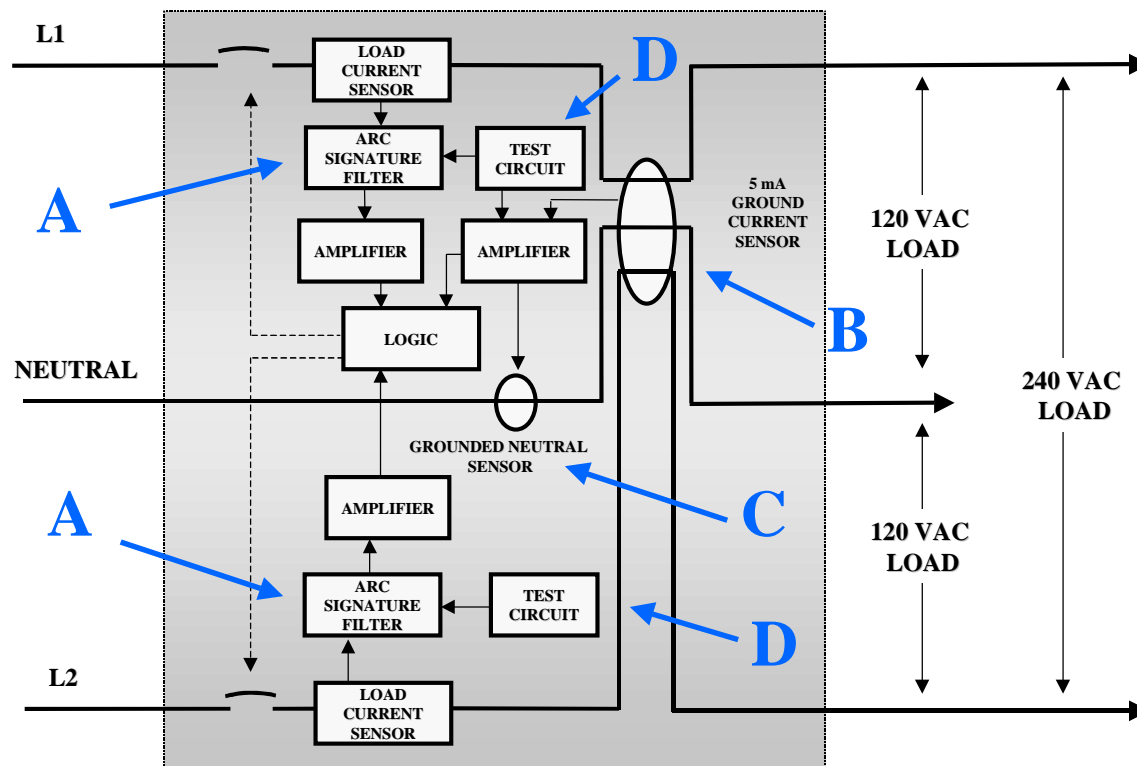

1. Two arc-fault sensing circuits (A) coupled to a common logic element that trips both poles when a hazardous arc fault is detected.
2. Grounded fault circuitry (B) including a neutral transformer (C), as required by UL943, that assures that the breaker trips should there be a wiring error in an outlet box that connects neutral and ground wires.
3. Three test buttons (D), one each for testing the arc detection circuitry of both phases, another for testing the 5 ma trip setting.

Appendix IV

References

1. “Technology for Detecting and Monitoring Conditions that Could Cause Electrical Wiring System Fires”, UL/CPSC report CPSC-C-94-112, September 1995.
2. “Glowing Contact Areas in Loose Copper Wire Connections,” J. Sletback, R. Kristensen, H. Sundklakk, Norwegian Institute of Technology; and G. Navik, M. Runde, Norwegian Electric Power Research Institute; Proceedings of the Thirty-Seventh IEEE Holm Conference on Electrical Contacts, 1991. And various Japanese reports on the causes of electrical fires summarized and translated by Yasuaki Hagimoto (NRIPS Japan) visiting VTT in Feb-Mar 1996. www.ozemail.cou.au/~tcforen/japan/index.html.
3. “Evaluations of Receptacle Connections and Contacts,” Proceedings of the IEEE Conference on Electrical Contacts, Jesse Aronstein, 1993.
4. “UL Special Services Investigation on Branch/Feeder Arc Fault Circuit Interrupter Incorporating Equipment Ground Fault Protection,” File E45310, May 31, 2001.
5. “Arc-fault Circuit Interrupters: New Technology for Increased Safety,” International Association of Electrical Inspectors News, J.C. Engel, R.J. Clarey, and T.M. Doring, Eaton | Cutler-Hammer, Pages 24-27, November/December 1997.
6. For additional information, refer to the email to the SAE AE-8B1 Protection Devices Subcommittee from Richard V. Wagner, P.E., Senior Research Engineer, Research Department, Underwriters Laboratory, Inc., July 13, 2001.